

CBS Arc Safe®

A Group CBS Company

USERS MANUAL

RRS-3-LAR1

A Portable Device for Remotely Racking LA-Style Circuit Breakers



Distance *is* Safety®

WHAT STANDS
BETWEEN YOU
AND ARC-FLASH
DANGER?

WE DO.

CBSArcSafe.com | Email: info@CBSArcSafe.com | **877-4-SAFETY** | Fax: 940-382-9435

Rev. October 2019

User's Manual for the RSK-3-LAR1 model (US Patent 9,520,248)

- 1.0 Arc-blast Hazards
- 2.0 Application Information
- 3.0 General Safety Information
- 4.0 Cables
- 5.0 Carrying Case
- 6.0 Controller
- 7.0 Power Supply
- 8.0 Installing and Removing Racking Motor
- 9.0 Sequence of Operation
- 10.0 Care and Storage
- 11.0 Specifications
- 12.0 Troubleshooting
- 13.0 Warranty

1.0 Arc-blast Hazards

The hazards associated with electrical arc-blasts are well documented. Studies conducted by numerous industries and professional organizations have sought to quantify the intensity of arc-blast, the risks to personnel, and various methodologies for mitigating the risks.

Without doubt, increasing the distance between the arc and a human is the single greatest favorable factor in reducing injuries.

Remote racking is not a panacea, but rather one more tool available for protecting workers while they are performing electrical switching.

Using the RRS-3-LAR1 remote racking device may not negate the need for additional personal protective measures. The user is ultimately responsible for evaluating each situation to determine if additional protective measures are needed.



WARNING

BREAKER RACKING MAY PRESENT RISK OF SERIOUS INJURY OR DEATH. THIS DEVICE SHOULD ONLY BE USED BY QUALIFIED PERSONS AFTER CAREFUL ANALYSIS OF THE HAZARDS.

2.0 Application Information

The RRS-3-LAR1 is suitable for most LA circuit breakers sold by Siemens and Siemens-Allis.

The same internal racking mechanism was utilized for all LA breakers, regardless of the frame size. The RRS-3-LAR1 should work with all LA breakers, 800 amp frame through 5000 amp frame.

DO NOT attempt to use the RRS-3-LAR1 with any breaker other than a LA.

3.0 General Safety Information

Carefully read and comply with all safety instructions listed below.

The RRS-3-LAR1 contains sealed lead-acid (SLA) batteries.

In the unlikely event of a battery rupture, treat all liquids and vapors as potentially hazardous (sulfuric acid).

Whenever the RRS-3-LAR1 is powered from an AC source, always use the (included) GFCI-equipped power cord. If the GFCI trips two consecutive times, discontinue AC-powered use and contact the factory.

Whenever the lid is open the unit must be protected from water intrusion.

Never close the carrying case while the unit is powered on.

4.0 Cables

4.1 Connecting and disconnecting the control cable

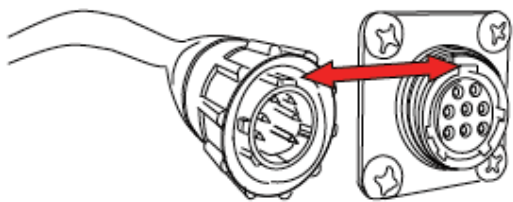

1. Align the keyway on the cable connector with the key on the power supply connector.
2. Push in and engage the thread on the coupling nut and turn clockwise.
3. Use a similar technique to connect the cable to the controller.

4.2 AC Power Cable / GFCI

ALWAYS use the GFCI-equipped power cable that was supplied with the RRS-3-LAR1. The automatic GFCI does not require resetting upon initial power-up. However, the GFCI should be tested prior to use by depressing the white TEST button. The GFCI should then trip. It is necessary to press the red Reset button before proceeding.

If the GFCI fails to trip when the Test button is depressed, DISCONTINUE AC-powered USE immediately and contact the factory.

If the GFCI tests properly without a load, but trips when a load is applied, a ground fault exists. A REAL SHOCK HAZARD EXISTS! Immediately discontinue use and contact the factory.

If the RRS-3-LAR1 is supplied from an extension cord, the GFCI cannot sense an upstream ground fault, i.e. a fault in the extension cord. For this reason, extension cords should be connected to a GFCI outlet or portable GFCI.

4.3 Racking Head Cable

The racking head cable is a high-quality, super-flexible, multiple conductor cable, with an overall braided shield. The racking head cable can easily be coiled and stored in the pocket toward the front of the carrying case.

Care should be taken to ensure the carrying case lid does not crush any of the cables.

5.0 Carrying Case

To lessen the chances of a tip over, the telescoping tag-along handle should be completely collapsed whenever the RLR1 is in use.



To safeguard against the case lid breaking the control cable connector, the lid latches should always be left in the 'down' position whenever the lid is open.

6.0 The Controller

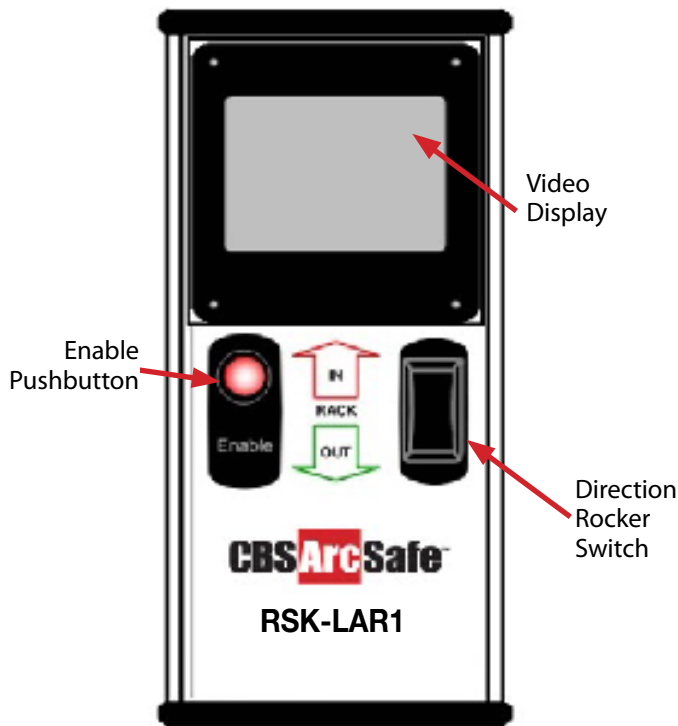

6.1 The ENABLE button

Upon initial power-up, the Enable button must be depressed for at least one second in order to advance to the next video screen.

6.2 The Rack IN / Rack OUT rocker switch

The rocker switch is used to select whether the racking motor racks the breaker IN or OUT. The rocker switch is spring return to center, OFF.

The Enable button and rocker switch must **BOTH** be HELD CONTINUOUSLY in order to run the racking motor.

6.3 Startup Screens

The video screen serves multiple functions.



Upon powering-up the RRS-3-LAR1, the introductory screen will appear. Pressing the Enable button for one second will advance the display to the next screen.

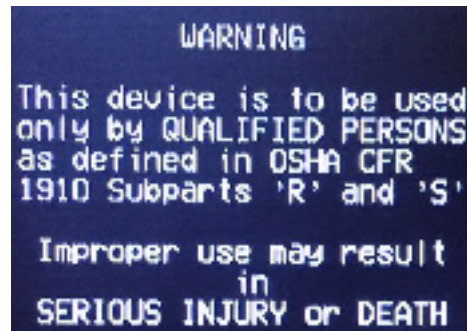

After reading the warning screen, once again depress the Enable button for one second to advance to the normal operating screen.

6.4 Operating Screen



The operating screen allows the user to constantly monitor the instantaneous torque being applied.

6.5 Torque Limiter Failure

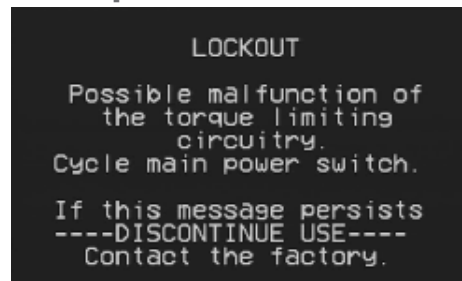

- The control circuitry is designed to allow a pre-determined maximum current to flow to the racking motor, thereby precisely controlling torque.
- An independent circuit, utilizing a Hall-effect current sensor, continuously monitors the amount of current flowing to the motor. This is used for the torque bar graph that is displayed on the graphic display.

- If the motor current exceeds a certain value the control system will inhibit ALL operations and display the message shown above.
- It is possible that a spurious current has falsely triggered this response. Simply turn the main power switch OFF and back ON. If the message appears again, discontinue using the device until the factory has been consulted.
- CONTINUED USE MAY RESULT IN BREAKER DAMAGE.

7.0 Power Supply

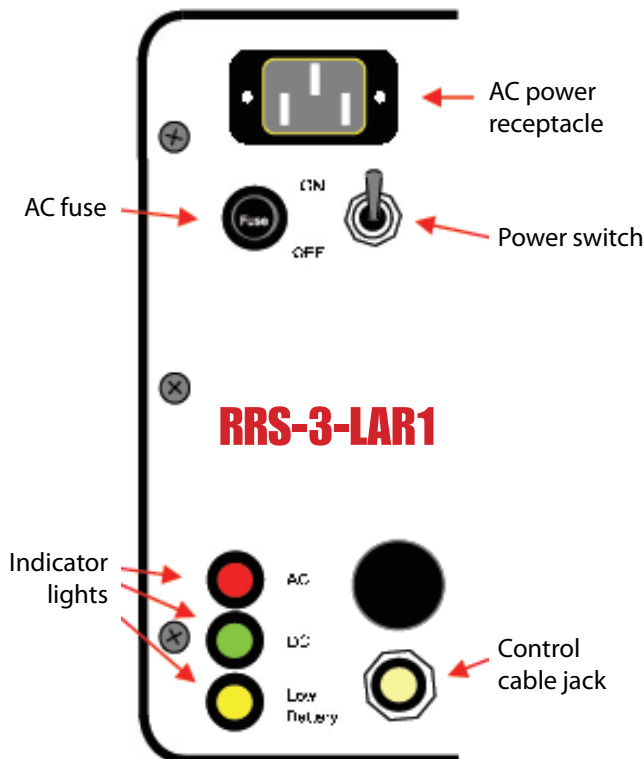

7.1 Power Supply Indicators

RED: indicates that AC power is present.

GREEN: indicates DC power is present.

YELLOW: indicates that DC voltage has fallen to approximately 21 volts and that the unit should be supplied from AC power as soon as possible. See section 7.4.

7.2 Power Supply Function

The RLR1 may be powered from either, the on-board batteries or from a 115 volt, 60 hz, AC source. If AC power is present, the power supply will automatically switch from batteries to the AC source and begin recharging the batteries.

Ensure the cooling fan exhaust is never restricted while the unit is powered on. NEVER completely close the case lid with power switch in the ON position.

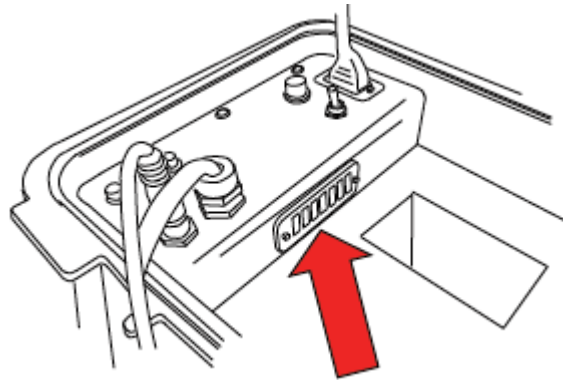

7.3 Recharging the Battery

In order to recharge the batteries, simply provide AC power and turn the power switch ON. The red AC indicator and green DC indicator should be illuminated and the cooling fan should be running. The control cable does not need to be plugged-in. Although the power supply regulates the charging voltage and current, it is preferred that the unit not be continuously charged for more than 24 hours.

8.0 The Racking Head

8.1 Key components of the Racking Head are as follows:

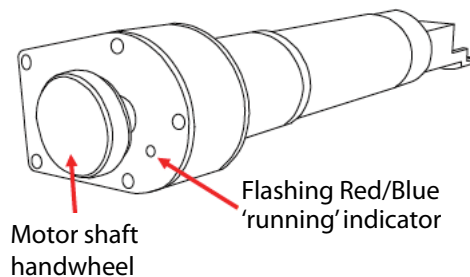
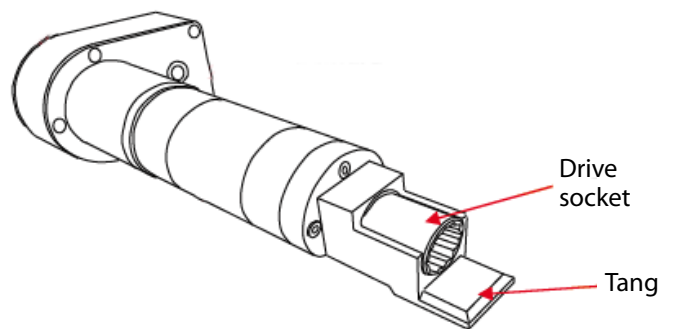

8.2 Engaging the Racking Motor to the Breaker Racking Mechanism

The racking head of the RRS-3-LAR1 MUST be installed using the technique described below.

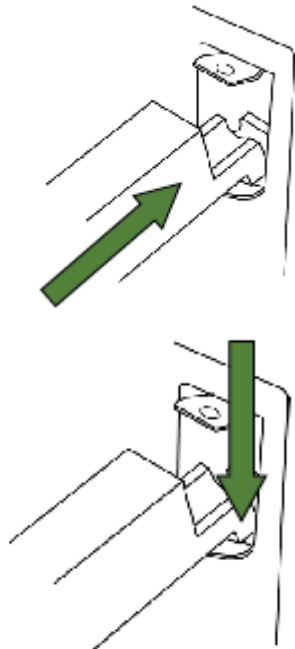

STEP 1: Insert the racking head at approximately 45 degrees.

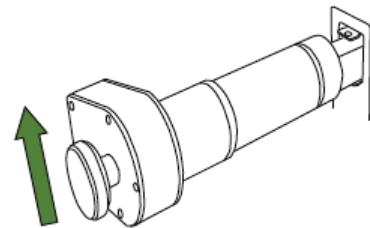

STEP 2: Insert the racking head until the lower tang drops down past the edge of the racking screw window.

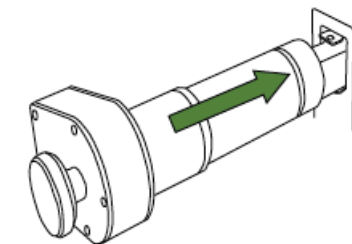

STEP 3: Rotate the rear of unit upward so that the rear is slightly higher than the racking head entering the breaker.

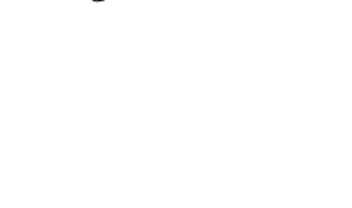

STEP 4: While holding the unit with the rear slightly higher than the racking head, push the unit toward the breaker, engaging the racking screw. The racking head tang will engage part of the racking screw mechanism when the racking unit is released to a level position. This will keep the unit from working out of the breaker during racking.

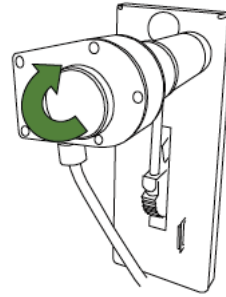

If engaging the drive socket is difficult, the handwheel can be rotated to reposition the drive socket slightly.

Typically, no more than 4 or 5 turns should be required.

8.3 Removing the Racking Motor from the Breaker

To remove the racking motor when racking is complete, slightly lift up on the rear of the racking motor and pull unit out to remove (Lifting up on the rear is necessary to allow the racking head tang to disengage the racking mechanism).

8.4 Racking to 'full in' or 'full out' Limits

The RRS-3-LAR1 electronically limits the amount torque that is applied to the racking mechanism. By observing the torque bar graph on the right side of the graphic display, the operator should notice an increase in torque as the breaker stabs are engaging the switchgear bus, as well as when the breaker is racked to either extreme limit (racked in or racked out).

Anytime the racking motor drives to a stalled condition, the control system will stop the motor and then reverse direction to back-off the racking mechanism by approximately 1/2 turn of the racking mechanism – provided both, the Enable button and Racking rocker switch are held. The graphic display will then indicate "Complete".

Additionally, the racking motor is equipped with a stall-sensor to sense motor stall. DO NOT be hesitant to run the racking motor to 'full stall' in either direction. To protect the racking motor, the control system limits the amount of time the motor can remain in a stalled condition, as well as limiting the motor current to a safe level.

9.0 Sequence of Operation

STEPS	SECTION
Connect the control cable to the power supply and handheld control unit.	4.1
If AC power is used, test the GFCI.	4.2
Power-up the power supply by turning toggle switch ON. The green 'DC' light should illuminate. If the unit is plugged into AC power, the red 'AC' should illuminate too. The cooling fan should be running. If the yellow 'Low DC' light comes on, plug the unit into an AC power source.	7.0
Observe the display on the handheld controller. Press the Enable button to acknowledge you have read the warnings and to advance to the next screen.	6.0
Engage the racking head to the breaker racking mechanism.	8.0
Standing outside the arc-flash boundary zone, depress the Enable button while simultaneously depressing the Racking rocker switch in the desired direction, i.e. Rack IN or Rack OUT.	6.0
Observe the video display to monitor the torque that is being applied.	6.4
Release either, the Enable button or the Racking rocker switch to stop the racking motor at any time.	6.1-6.2
If the Enable button and Racking rocker switch are held continuously, once the motor drives to a stalled condition, it will automatically stop, and reverse directions until the racking nut (socket) turns approximately 1/2 turn. The display will then say "Complete".	8.2

10.0 Care and Storage

The RLR1 contains no user-serviceable parts. The sealed lead-acid batteries should be replaced at 24-month intervals. Contact the factory.

11.0 Specifications

MECHANICAL	
Gearmotor theoretical max torque	36 ft. lbs.
Gearmotor torque limit factor	22 ft. lbs.
Total unit weight	35 lbs.
ELECTRICAL	
AC Input voltage	115 volts, 60 Hz
AC Fuse type	3 amp, 4AG
Battery voltage	24 volts
Gearmotor voltage	24 volts
Max battery charging current	500 ma
Battery capacity	3.2 Ahr
Battery type	sealed lead-acid

12.0 Troubleshooting Guide

SYMPTOM	ACTION
Graphic display doesn't startup properly.	Turn power supply switch OFF, wait 3-seconds, turn power supply switch ON.
Unit goes into "Lockout" and displays a message saying the "torque limiting circuitry" may have failed.	Cycle power OFF/ON If "Lockout" recurs, discontinue use, and contact the factory.
GFCI trips.	Disconnect power cable from the RRS-3-LAR1. Reset GFCI. If the GFCI will not reset, either the GFCI or the power cord is defective. If the GFCI only trips when the power cord is plugged into the RRS-3-LAR1, there is an internal fault. Contact the factory.

13.0 Warranty

CBS ArcSafe guarantees all products manufactured by CBS ArcSafe only against defects in materials and/or workmanship for a period of twelve (12) months commencing on the date the product is received by the customer. THIS WARRANTY IS IN LIEU OF ALL OTHER EXPRESS OR IMPLIED WARRANTIES INCLUDING THOSE OF MERCHANTABILITY AND FITNESS FOR A PARTICULAR PURPOSE.

CBS ArcSafe will, at its option and its cost (excluding shipping expenses), repair, replace or refund the purchase price of any product manufactured by CBS ArcSafe which has a defect in materials and/or workmanship. THIS IS CUSTOMER'S EXCLUSIVE REMEDY FOR BREACH OF WARRANTY. IN NO EVENT WILL CBS ARC SAFE LIABILITY FOR DAMAGES (WHETHER ARISING FROM BREACH OF CONTRACT OR WARRANTY, NEGLIGENCE, STRICT LIABILITY OR OTHERWISE) EXCEED THE PURCHASE PRICE OF THE PRODUCT CONCERNED NOR WILL CBS ARC SAFE BE LIABLE FOR PUNITIVE, INCIDENTAL, CONSEQUENTIAL OR SPECIAL DAMAGES (INCLUDING WITHOUT LIMITATION LOST PROFITS) EVEN IF ADVISED OF THE POSSIBILITY OF SUCH DAMAGES.

CBS ArcSafe reserves the right to disallow warranty repairs if the unit has been disassembled or misused, as determined by CBS ArcSafe in good faith. Please contact us at (877)-472-3389 for a return authorization.



Worldwide Headquarters & U.S. Sales

CBS ArcSafe, Inc. A Group CBS Company
2616 Sirius Road | Denton, TX 76208
Ph: 877-4-SAFETY | Ph: 940-382-4411 | Fx: 940-382-9435
info@CBSArcSafe.com

Charleston, WV Facility

4782 Chimney Drive | Charleston, WV 25302
Ph: 800-248-4958 | Ph: 304-965-9220 | Fx: 304-965-9221

U.K. /Europe Office

27 Cressey Avenue | Shenley Brook End
Milton Keynes, Buckinghamshire
United Kingdom MK57EL
Phone: +447 770 500577