



A Group CBS Company

USERS MANUAL

RSK-DS10

A Portable Actuator for Remotely Operating 'DS-style' Low Voltage Circuit Breakers



Distance *is* Safety[®]

WHAT STANDS
BETWEEN YOU
AND ARC-FLASH
DANGER?

WE DO.

CBSArcSafe.com | Email: info@CBSArcSafe.com | **877-4-SAFETY** | Fax: 940-382-9435

Rev. September 2019

User's Manual for the RSK-DS10 model

- 1.0 Arc-blast Hazards
- 2.0 Application Information
- 3.0 Safety Information
- 4.0 Battery Information
- 5.0 Control Cable
- 6.0 Controller
- 7.0 Neutral Interlock
- 8.0 Attaching and Removing the Actuator
- 9.0 Sequence of Operation
- 10.0 Care and Storage
- 11.0 Warranty
- 12.0 Care and Storage
- 13.0 Troubleshooting

1.0 Arc-blast Hazards

The hazards associated with electrical arc-blasts are well documented. Studies conducted by numerous industries and professional organizations have sought to quantify the intensity of arc-blast, the risks to personnel, and various methodologies for mitigating the risks.

Without doubt, increasing the distance between the arc and a human is the single greatest favorable factor in reducing injuries.

The Chicken Switch® is not a panacea but rather one more tool available for protecting workers while they are performing electrical switching.

Using a Chicken Switch® may not negate the need for additional personal protective measures. The user is ultimately responsible for evaluating each situation to determine if additional protective measures are needed.



WARNING

**ELECTRICAL SWITCHING
MAY PRESENT RISK OF
SERIOUS INJURY OR DEATH.
THIS DEVICE SHOULD ONLY
BE USED BY QUALIFIED
PERSONS AFTER CAREFUL
ANALYSIS OF THE HAZARDS.**

2.0 Application Information

The DS-10 is suitable for most 'DS-style' circuit breakers manufactured by Westinghouse, Cutler-Hammer and Square D.

The same stamping (i.e. physical arrangement of the pull handle, trip button and close bar) was utilized for all DS breakers, regardless of the frame size. The DS-10 should work with all DS breakers, 800 amp frame through 5000 amp frame.

It is imperative that the face plate of the DS breaker is fully secured to the breaker and is in good condition. The portion of the breaker faceplate that is contacted by the DS-10 must be free of dirt and obstructions such as laminated labels or other non-OEM objects.

3.0 Safety Information

ALWAYS connect the control cable to the actuator and controller BEFORE installing the Chicken Switch®.

3.1 Finger pinch points

Use caution when attaching the Chicken Switch® to the breaker or while placing it near a ferrous surface.

NEVER place a finger in the openings on the bottom of the Chicken Switch®.

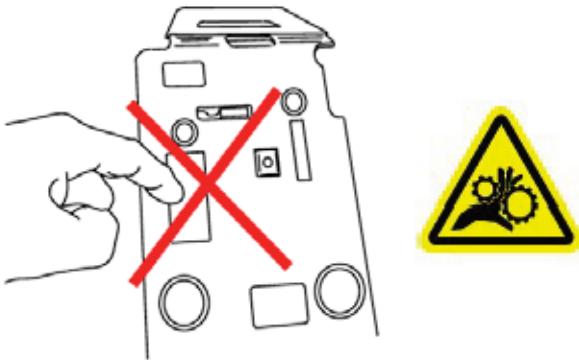

3.2 CAUTION: Strong magnets

Keep fingers clear of the bottom of the actuator when the actuator is near a ferrous surface.

The holding magnets are very strong. Avoid placing the Chicken Switch® near electro-mechanical protective relays.

4.0 Battery Information

4.1 Battery Requirements

- Sixteen (16) AA alkaline cells are required –eight cells in each battery holder. Carefully observe polarity when installing cells.
- Rechargeable NiMh or NiCd batteries can be used.

4.2 Battery Life

- A set of fresh alkaline cells should yield hundreds of operations.
- The Chicken Switch® is designed as a portable device. It is not designed to remain with the control unit connected to the actuator for extended periods of time. To do so will deplete a fresh set of batteries in approximately four to five days.

4.3 Battery Replacement

- ALWAYS disconnect the control cable before replacing batteries to avoid possible static damage of the electronics!
- Turn the control station upside down, remove the endplate retaining knob. Remove the endplate and slide the cover out as shown.

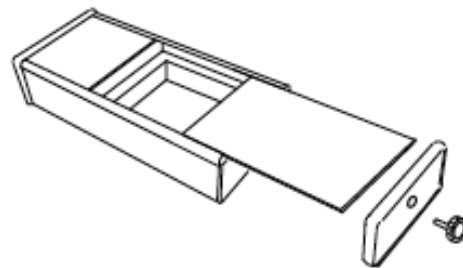

4.3a To connect/disconnect batteries

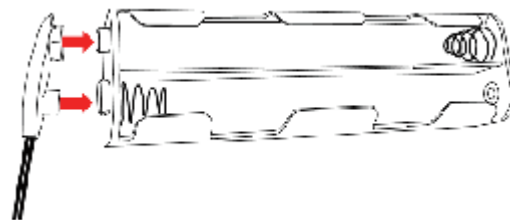

4.3b CAUTION: Static Discharge Potential

- To avoid possible damage to electronic components disconnect the control cable before replacing batteries.

4.3c Installing Batteries

- When installing batteries, push the batteries toward the positive terminal to ensure the top of the battery firmly contacts the battery holder terminal.

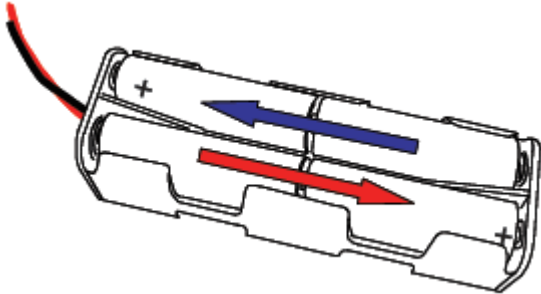

5.0 Control Cable

5.1 Connecting the control cable



1. Align the arrow on the cable end with the top of the receptacle.
2. Push in and engage the threads on the coupling nut and turn clockwise.
3. After one or two turns of the coupling nut, push in on the cable end. Repeat this until the connector is fully seated.
4. Use a similar technique of turn-stop-and-pull to disengage the cable ends.

NOTE: When the actuator is connected to the control station, the actuator will automatically drive to the neutral position if it is not already in this position (i.e., neither the 'trip' nor 'close' function will be activated).

6.0 The Controller

The controller is designed for two-hand operation for the purpose of preventing inadvertent operation of the actuator. See the following section for a detailed description of the controller indicators and switches.

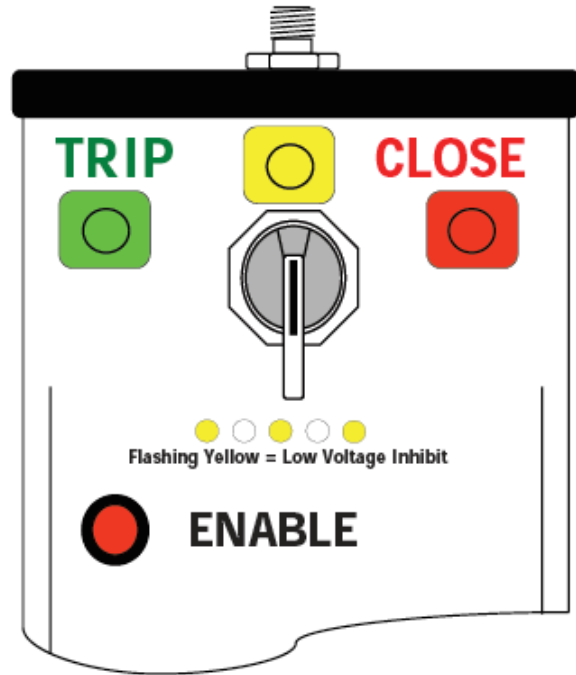

6.1 The indicator lights & controls:

NOTE: The indicator lights only work when the ENABLE button is depressed.

GREEN: indicates the actuator is being commanded to depress the TRIP button.

RED: indicates the actuator is being commanded to depress the CLOSE button.

YELLOW: indicates the actuator is in the neutral position and the controller and batteries are healthy.

Rapidly **blinking YELLOW** indicates the battery voltage with zero load has fallen to an unacceptable level. Operation is inhibited until batteries with an acceptable voltage level are installed.

The ENABLE button:

The Enable button must be continuously depressed in order to command the actuator.

Releasing the enable button has the same affect as releasing either the ON or OFF buttons – both actuators will move to the retracted position.

The Control Switch:

The control switch is used to activate the Chicken Switch actuator to Trip or Close the breaker. The Control Switch is spring return to center. Turning the switch clockwise will close the breaker, counter-clockwise will trip the breaker.

If the Control Switch is held in the trip or close position for longer than approximately 3 seconds the drive motor will de-energize and the actuator will remain in the driven position. When the Control Switch or the Enable button is released, the motor will energize to drive the actuator to the neutral position.

7.0 Neutral Interlock Function

To avoid an inadvertent breaker operation, a mechanical safety interlock is provided to prevent the installation of the Chicken Switch® if the actuator is NOT in the neutral position.

Jarring the actuator may cause the Neutral Interlock to extend. This is normal. See the section below for instructions and precautions.

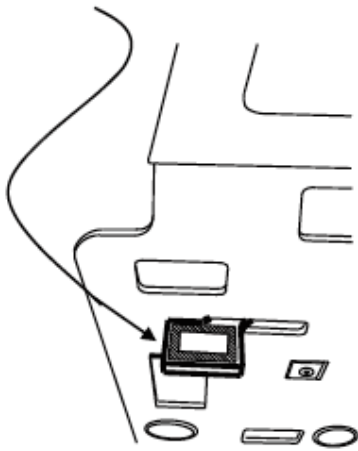

7.1 Neutral Interlock Reset

With the controller connected to the actuator, rotate the interlock to the fully retracted position. If the actuator is in the neutral position a holding magnet will retain the interlock.

DO NOT attempt to install the actuator on the breaker if the interlock will not stay in the retracted position. Refer to the Troubleshooting Guide in the back of this manual.



8.0 Attaching and Removing the Actuator

8.1 To Attach the Actuator

1. While holding the Chicken Switch® by the red handle, align the slots in the base of the Chicken Switch® with the pullhandle on the face of the circuit breaker.
2. Rotate the top of the Chicken Switch® toward the breaker until it is held flush against the face of the circuit breaker by the holding magnets.

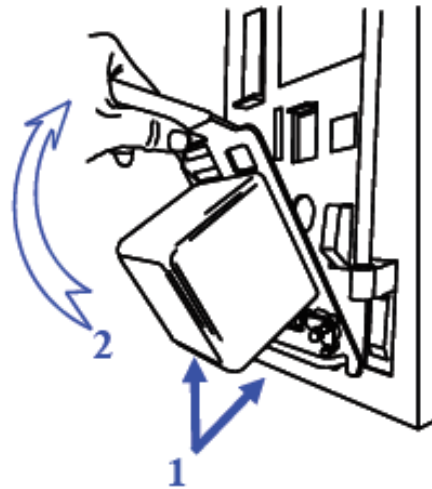

WARNING FOR 'DSL' BREAKERS (EQUIPPED WITH CURRENT LIMITERS).

The 'blown current limiter' indicators and 'Reset' plunger **MUST NOT be obstructed**. Obstructing an indicator or the reset button could cause the breaker to fail to open in the event of a blown current limiter.

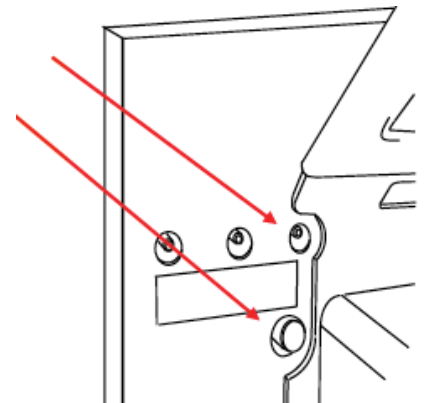

8.2 To Remove the Actuator

To remove:

Grasp the red handle on the top of the Chicken Switch® and pull the top of the actuator away from the breaker. Once the magnets have separated from the switchgear enclosure, lift the actuator clear of the breaker.

NOTICE: Jarring the actuator may cause the Neutral Interlock to extend. This is normal and it will easily reset if the actuator is in the neutral position. See the section 7.0 for further instructions and precautions.

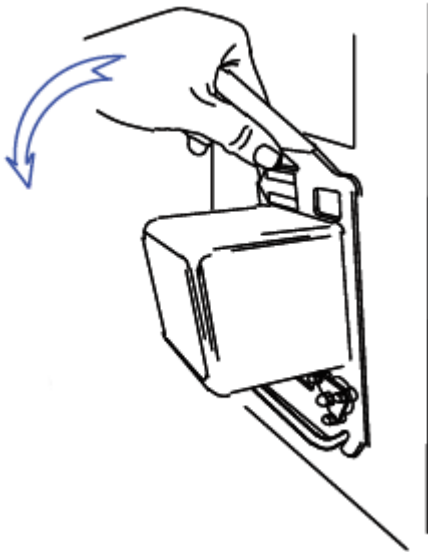

9.0 Sequence of Operation

| STEPS | SECTION |
|--|---------|
| 1. Connect the control cable to the Actuator first. Then connect the other end to the Control Station. Note that the actuator will move to the neutral position if it is not already in this position. | 5.0 |
| 2. Verify that the Neutral Interlock stays in the retracted position. | 7.1 |
| 3. Attach the actuator to the breaker. | 8.1 |
| 4. If the intended action is to close the circuit breaker, charge the breaker by operating the spring charging handle the required number of strokes. Verify the yellow "Spring Charged" flag is visible near the bottom of the breaker. | |
| 5. Ensure you are at a safe distance from the circuit breaker that is to be operated. Note: The user must determine the safe distance based on NFPA 70E requirements. | |
| 6. When ready to operate the breaker, press and hold the ENABLE button. | 6.1 |
| 7. The yellow light should illuminate whenever the ENABLE button is depressed, indicating the battery voltage is acceptable and the actuator is in the neutral position. | 6.1 |
| 8. While holding the ENABLE button, operate the Control Switch on the Control Station in the appropriate direction for the desired action – trip or close. | 6.1 |
| 9. Release the ENABLE button and control switch after the breaker has operated. | 6.1 |
| 10. Remove the actuator from the breaker. | 8.2 |

10.0 Care and Storage

10.1 Cleaning the Magnets

Over a period of time, the magnets may attract ferrous debris. Exercise care to avoid setting the actuator where the magnets might attract debris. If this does occur, use a paper towel or nylon bristle brush to clean the face of the magnets. Keeping the magnet faces clean ensures that maximum holding power is maintained.

10.2 Storage

- Remove all batteries from the control station if the device will not be used for longer than 6 months.
- Never store the batteries where the ambient temperature might exceed 110° F.
- Avoid getting the unit wet or storing it in a high humidity location. Store in a dry location.
- Store the unit in its carrying case.

11.0 Warranty

CBS ArcSafe® guarantees all products manufactured by CBS ArcSafe® only against defects in materials and/or workmanship for a period of twelve (12) months commencing on the date the product is received by the customer. THIS WARRANTY IS IN LIEU OF ALL OTHER EXPRESS OR IMPLIED WARRANTIES INCLUDING THOSE OF MERCHANTABILITY AND FITNESS FOR A PARTICULAR PURPOSE.

CBS ArcSafe® will, at its option and its cost (excluding shipping expenses) repair, replace or refund the purchase price of any product manufactured by CBS ArcSafe® which has a covered defect in materials and/or workmanship. THIS IS CUSTOMER'S EXCLUSIVE REMEDY FOR BREACH OF WARRANTY. IN NO EVENT WILL CBS ARCSAFE'S® LIABILITY FOR DAMAGES (WHETHER ARISING FROM BREACH OF CONTRACT OR WARRANTY, NEGLIGENCE, STRICT LIABILITY OR OTHERWISE) EXCEED THE PURCHASE PRICE OF THE PRODUCT CONCERNED NOR WILL CBS ARCSAFE® BE LIABLE FOR PUNITIVE, INCIDENTAL, CONSEQUENTIAL OR SPECIAL DAMAGES (INCLUDING WITHOUT LIMITATION LOST PROFITS) EVEN IF ADVISED OF THE POSSIBILITY OF SUCH DAMAGES.

This warranty does not cover damage caused by accident, improper care, negligence, normal wear and tear, natural causes, unlicensed repairs, and incompetent supervision. This warranty also does not cover repairs or replacements made by unauthorized individuals except when agreed to in writing. CBS ArcSafe® reserves the right to disallow warranty repairs if the unit has been disassembled or misused, as determined by CBS ArcSafe® in good faith. Please contact us at (877) 472-3389.

12.0 Specifications

| MECHANICAL | |
|-------------------|--|
| Holding magnets | Four neodymium rare earth magnets, two rated @ 55.1 lbs force each and two magnets rated at 19.71 lbs force each. |
| Gearmotor | All metal gears, in a formed metallic housing. DC brushed, permanent magnet motor with .375 inch diameter shaft (9.5 mm). |
| Projected life | 20,000 operations |
| ELECTRICAL | |
| Operating voltage | 24 volts DC |
| Fuse | 5 amp, quick-blow, AGC-5 |
| Power supply | 16 AA alkaline disposable batteries. When used properly, one set of batteries should yield over 500 operations. |
| Control cable | 30 feet in length (9.1 meters), 5-conductor, extra-flexible, PUR insulation. Optional 50' cable. |
| Controller | Requires two-hand operation. The 'enable' button must be depressed while rotating the controller selector switch. A programmable micro-controller manages control inputs, motor functions, monitors and limits mechanical travel and performs timing functions to protect the motor in a stalled condition. An intelligent 'H-bridge' motor driver provides start/stop/braking motor functions. The H-bridge has integral thermal shutdown protection. |

13.0 Troubleshooting Guide

1. Neutral interlock will not reset.
This means the actuator is not in the 'mechanical neutral' position.
 - Connect the controller to the actuator.
 - The yellow LED should light when the Enable Button is depressed.
 - Rotate the neutral interlock to the retracted position.
 - If the interlock will not stay in the retracted position, do not use the unit. Contact the factory.
2. The Chicken Switch seems to operate, but my breaker doesn't.
 - If the Chicken Switch is pressing the trip and close buttons but the breaker does not operate, there may be a problem with the breaker.
 - Or, the breaker manufacturer may have disabled the close button at the customer's request. If the Chicken Switch pulls away from the breaker when trying to close the breaker and the breaker does not close, your close button may be disabled. Please contact us for a possible solution.
3. The Chicken Switch will not operate. The yellow LED flashes rapidly whenever the Enable Button is depressed.
 - This is caused by a 'low voltage lockout'. Replace the batteries.



Worldwide Headquarters & U.S. Sales

CBS ArcSafe, Inc. A Group CBS Company
2616 Sirius Road | Denton, TX 76208
Ph: 877-4-SAFETY | Ph: 940-382-4411 | Fx: 940-382-9435
info@CBSArcSafe.com

Charleston, WV Facility

4782 Chimney Drive | Charleston, WV 25302
Ph: 800-248-4958 | Ph: 304-965-9220 | Fx: 304-965-9221

U.K. /Europe Office

27 Cressey Avenue | Shenley Brook End
Milton Keynes, Buckinghamshire
United Kingdom MK57EL
Phone: +447 770 500577