



A Group CBS Company

## USERS MANUAL

# RSK-GEPB1 and RSK-GEPB1E

## A Portable Actuator for Remotely Operating General Electric Power Break I Circuit Breakers

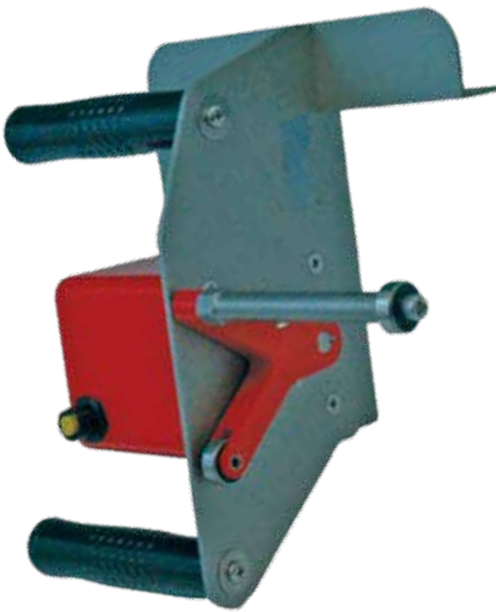

# Distance *is* Safety<sup>®</sup>

WHAT STANDS  
BETWEEN YOU  
AND ARC-FLASH  
DANGER?

# WE DO.

[CBSArcSafe.com](http://CBSArcSafe.com) | Email: [info@CBSArcSafe.com](mailto:info@CBSArcSafe.com) | **877-4-SAFETY** | Fax: 940-382-9435

Rev. January 2020

## User's Manual for RSK-GEPB1 and RSK-GEPB1E

- 1.0 Arc-blast Hazards
- 2.0 Safety Information
  - 2.1 Finger pinch points
  - 2.2 Strong magnets
- 3.0 Battery Information
  - 3.0 Battery Requirements
  - 3.1 Battery Life
  - 3.2 Battery Replacement
  - 3.3 Connecting/Disconnecting Batteries
  - 3.4 Static Discharge Potential
- 4.0 Operation
  - 4.1 Connecting the control cable
  - 4.2 Sequence of operation
  - 4.3 Attaching and removing the actuator
  - 4.4 Indicator lights
- 5.0 Care and Storage
  - 5.1 Cleaning debris from magnets
  - 5.2 Storage
- 6.0 Warranty
- 7.0 Specifications

### 1.0 Arc-blast Hazards

The hazards associated with electrical arc-blasts are well documented. Studies conducted by numerous industries and professional organizations have sought to quantify the intensity of arc-blast, the risks to personnel, and various methodologies for mitigating the risks.

Without doubt, increasing the distance between the arc and a human is the single greatest favorable factor in reducing injuries.

The Chicken Switch® is not a panacea but rather one more tool available for protecting workers while they are performing electrical switching.

Using a Chicken Switch® may not negate the need for additional personal protective measures. The user is ultimately responsible for evaluating each situation to determine if additional protective measures are needed.



### WARNING

**ELECTRICAL SWITCHING  
MAY PRESENT RISK OF  
SERIOUS INJURY OR DEATH.  
THIS DEVICE SHOULD ONLY  
BE USED BY QUALIFIED  
PERSONS AFTER CAREFUL  
ANALYSIS OF THE HAZARDS.**

## 2.0 Safety Information

ALWAYS connect the control cable to the actuator BEFORE installing the Chicken Switch®.

### 2.1 Finger pinch points

NEVER place your fingers or other body parts below between the Close arm and top angle when the control station is connected to the actuator. The actuator arm could pinch your hand/body part against the angle. Keep fingers clear of the bottom of the actuator when the actuator is near a ferrous surface.

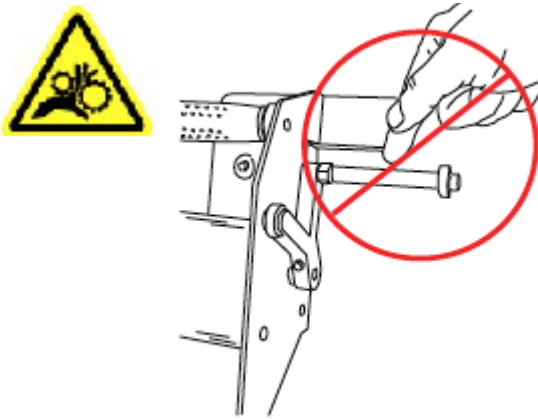

### 2.2 Strong magnets

The holding magnets are very strong. Keep magnetically-sensitive objects such as watches or computer disks away from the bottom of the actuator.

### 3.0 Battery Requirements

- Sixteen (16) AA alkaline cells are required – eight cells in each battery holder. Carefully observe polarity when installing cells.
- Rechargeable NiMh or NiCd can be used.

### 3.1 Battery Life

- A set of fresh alkaline cells should give over 700 operations.
- The Chicken Switch® is designed as a portable device. It is not designed to remain with the control unit connected to the actuator for extended periods of

time. To do so will deplete a fresh set of batteries in approximately four to five days.

### 3.2 Battery Replacement

- ALWAYS disconnect the control cable before replacing batteries to avoid possible static damage of the electronics!
- Turn the control station upside down, remove the endplate retaining knob. Remove the endplate and slide the cover out as shown.

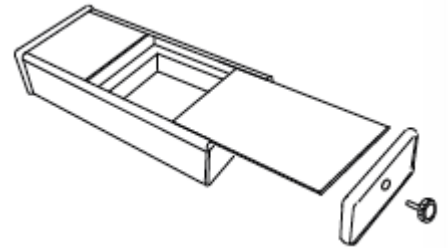

### 3.3 To connect/disconnect batteries:

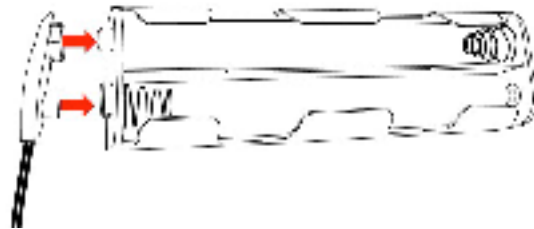

### 3.4 CAUTION: Static Discharge Potential

- To avoid possible damage to electronic components disconnect the control cable before replacing batteries.

## WARNING

**TO AVOID POSSIBLE  
DAMAGE TO ELECTRONIC  
COMPONENTS DISCONNECT  
CONTROL CABLE BEFORE  
REPLACING BATTERIES.**

### 4.0 Operation

ALWAYS connect the control cable to the actuator BEFORE

installing the Chicken Switch®.



## 4.1 Connecting the control cable

1. Align the arrow on the cable end with the top of the receptacle.
2. Push in and engage the threads on the coupling nut and turn clockwise.
3. After one or two turns of the coupling nut, push in on the cable end. Repeat this until the connector is fully seated.
4. Use a similar technique of turn-stop-and-pull to disengage the cable ends.

## 4.2 Sequence of Operation:

1. If the breaker needs to be charged, DO NOT charge it until the RSK-GEPB1 has been installed. See Step #5.
2. Connect the control cable to the actuator.
3. Connect the control cable to the hand-hand controller. As soon as the cable is connected, the actuator will move to the neutral position if it is not already in that position.
4. Position the actuator on the circuit breaker control switch that is to be operated. See the diagrams on the following pages for proper method to install.
5. The RSK-GEPB1 is designed so that the breaker can be charged after it is installed. It is **HIGHLY RECOMMENDED** to charge the breaker after installation to help reduce the possibility of inadvertently closing the breaker when installing the RSK-GEPB1.
6. Ensure you are at a safe distance from the circuit breaker that is to be operated.
7. When ready to operate the actuator, press and **HOLD** the **ENABLE** button while rotating the control switch to the **TRIP** or **CLOSE** direction for the desired operation. The **ENABLE** button must be held depressed until the actuator has fully operated.
8. Release the **ENABLE** button and control switch and the actuator will retract.
9. The RSK-GEPB1 can now be removed.

## 4.3 Attaching and Removing the Actuator:

**Step #1:** Using two hands, position the GEPB-1 on the top left corner of the breaker with the bottom of the GEPB-1 tilted outward.

**Step #2:** Assure that the corner of the alignment angles on the GEPB-1 are seated firmly against the top left corner of the breaker face.

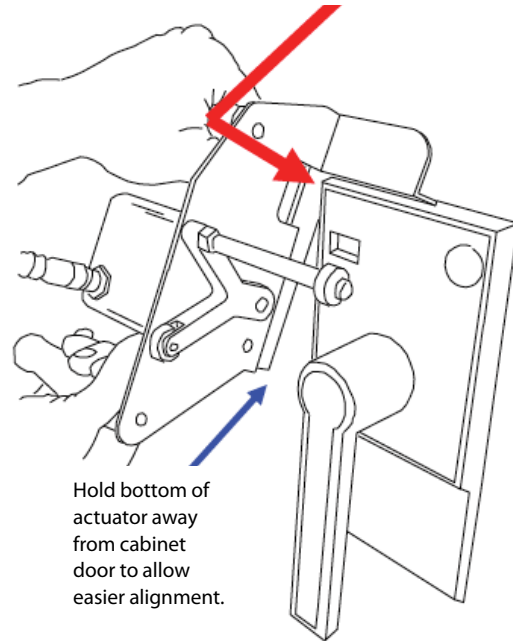

**Step #3:** While holding the GEPB-1 firmly, tilt the bottom towards the breaker until the magnets engage the cabinet door.

The GEPB-1 must align firmly against the breaker face on the **TOP** and the **SIDE**.

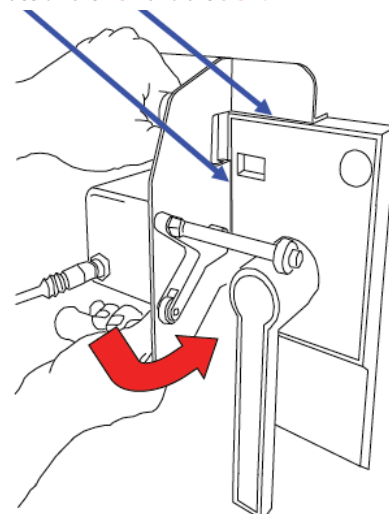

**Step #4:** Use opening in the frame to visually verify that the GEPB-1 is in place against the breaker side.

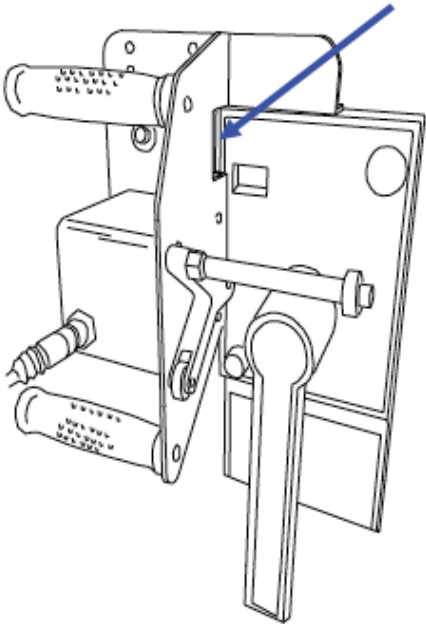

**Step #5:** The GEPB-1 has been properly installed. Follow the Steps 5 and 6 in Section 4.2 to operate the breaker.

**To REMOVE ACTUATOR:** While firmly holding the actuator with two hands, pull the bottom away from the cabinet door to release the magnets and carefully remove the actuator from the breaker.

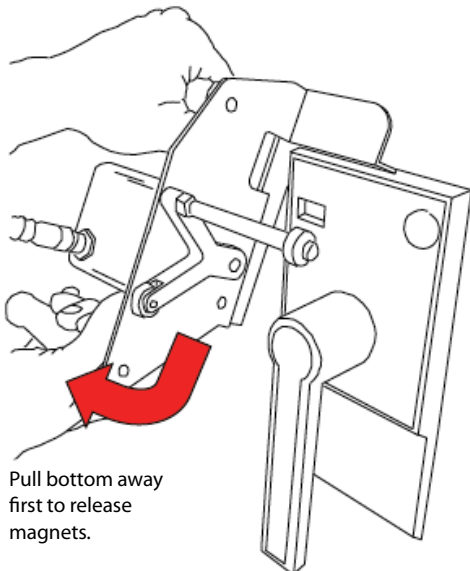

Pull bottom away first to release magnets.

## 4.4 The indicator lights & controls:

**NOTE:** Red and Green indicator lights only work when the ENABLE button is depressed.

**GREEN:** indicates the actuator is being commanded to rotate in the TRIP direction.

**RED:** indicates the actuator is being commanded to rotate in the CLOSE direction.

**YELLOW:** indicates the actuator is in the neutral position and the controller and batteries are healthy.

Rapidly **blinking YELLOW** indicates the battery voltage with zero load has fallen to an unacceptable level. Operation is inhibited until batteries with an acceptable voltage level are installed.

### The ENABLE button:

The Enable button must be continuously depressed in order to command the actuator.

Releasing the enable button has the same affect as returning the selector switch to neutral – the actuator moves to neutral.

**NOTE:** If the control switch is held in the trip or close position for longer than approximately 3 seconds the drive motor will de-energize and the arm will remain in driven position. When the control switch or the enable button is released, the motor will energize to drive the actuator arm to neutral.

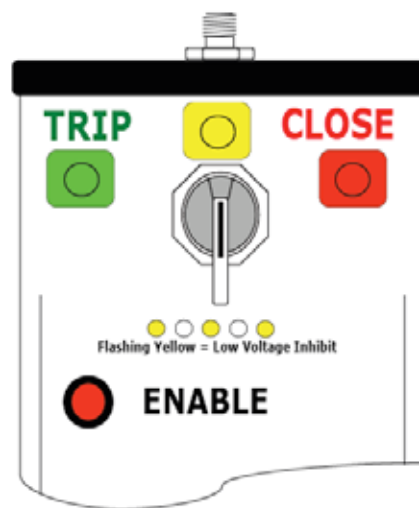

## 5.0 Care and Storage

### 5.1 Cleaning the magnets

Over a period of time, the magnets may attract ferrous debris. Exercise care to avoid setting the actuator where the magnets might attract debris. If this does occur, use a paper towel or nylon bristle brush to clean the face of the magnets. Keeping the magnet faces clean ensures that maximum holding power is maintained.

### 5.2 Storage

Remove all batteries from the control station if the device will not be used for longer than 6 months. Never store the batteries where the ambient temperature might exceed 110° F. Avoid getting the unit wet or storing it in a high humidity location.

## 6.0 Warranty

CBS ArcSafe® guarantees all products manufactured by CBS ArcSafe® only against defects in materials and/or workmanship for a period of twelve (12) months commencing on the date the product is received by the customer. THIS WARRANTY IS IN LIEU OF ALL OTHER EXPRESS OR IMPLIED WARRANTIES INCLUDING THOSE OF MERCHANTABILITY AND FITNESS FOR A PARTICULAR PURPOSE.

CBS ArcSafe® will, at its option and its cost (excluding shipping expenses) repair, replace or refund the purchase price of any product manufactured by CBS ArcSafe® which has a covered defect in materials and/or workmanship. THIS IS CUSTOMER'S EXCLUSIVE REMEDY FOR BREACH OF WARRANTY. IN NO EVENT WILL CBS ARCSAFE'S® LIABILITY FOR DAMAGES (WHETHER ARISING FROM BREACH OF CONTRACT OR WARRANTY, NEGLIGENCE, STRICT LIABILITY OR OTHERWISE) EXCEED THE PURCHASE PRICE OF THE PRODUCT CONCERNED NOR WILL CBS ARCSAFE® BE LIABLE FOR PUNITIVE, INCIDENTAL, CONSEQUENTIAL OR SPECIAL DAMAGES (INCLUDING WITHOUT LIMITATION LOST PROFITS) EVEN IF ADVISED OF THE POSSIBILITY OF SUCH DAMAGES.

This warranty does not cover damage caused by accident, improper care, negligence, normal wear and tear, natural

causes, unlicensed repairs, and incompetent supervision. This warranty also does not cover repairs or replacements made by unauthorized individuals except when agreed to in writing. CBS ArcSafe® reserves the right to disallow warranty repairs if the unit has been disassembled or misused, as determined by CBS ArcSafe® in good faith. Please contact us at (877) 472-3389.

## 7.0 Specifications

| MECHANICAL        |  |
|-------------------|--|
| Holding magnets   | Two magnets, each rated @ 55.1 lbs force, 12,600 Gauss.  |
| Gearmotor         | All metal gears, in a formed metallic housing. DC brushed, permanent magnet motor with .375 inch diameter shaft (9.5 mm).  |
| Torque            | Approximately 35 inch-pounds (7.9 N-m)   |
| Projected Life    | 20,000 operations  |
| ELECTRICAL        |  |
| Operating voltage | 24 volts DC  |
| Fuse              | 4 amp, quick-blow, AGC-4   |
| Power supply      | 16 AA alkaline disposable batteries. When used properly, one set of batteries should yield over 700 operations.  |
| Control Cable     | 30 feet in length (9.1 meters), 5-conductor, extra-flexible, PUR insulation  |
| Controller        | Requires two-hand operation. The 'enable' button must be depressed while rotating the controller selector switch. A programmable micro-controller manages control inputs, motor functions, monitors and limits mechanical travel and performs timing functions to protect the motor in a stalled condition. An intelligent 'H-bridge' motor driver provides start/stop/braking motor functions. The H-bridge has integral thermal shutdown protection. |

### Worldwide Headquarters & U.S. Sales

CBS ArcSafe, Inc. A Group CBS Company  
2616 Sirius Road | Denton, TX 76208  
Ph: 877-4-SAFETY | Ph: 940-382-4411  
Fx: 940-382-9435

[info@CBSArcSafe.com](mailto:info@CBSArcSafe.com)

### Charleston, WV Facility

4782 Chimney Drive | Charleston, WV 25302  
Ph: 800-248-4958 | Ph: 304-965-9220 | Fx: 304-965-9221

### U.K. /Europe Office

27 Cressey Avenue | Shenley Brook End  
Milton Keynes, Buckinghamshire  
United Kingdom MK57EL | Phone: +447 770 5005